



TOPSTAR TECHNOLOGY INDUSTRIAL CO., LIMITED

产 品 规 格 书

Product Specification Sheet

TOP-BIDI-SFP+-ER-27

RoHS Compliant 10Gb/s Tx1270/Rx1330nm 40km BIDI Optical Transceiver



Email: asale@topsf.com





PRODUCT FEATURES

- SFPMS A package with duplex LC connector
- Very low EMI and excellent ESD protection
- Digital Diagnostic Monitor Interface
- Hot pluggable
- 10Gb/s serial optical interface
- Up to 40km distance
- Compliant with SFP+ MSA
- High transmission margin
- +3.3V single power supply
- Below<1.5W power consumption
- SFP mechanical interface

APPLICATIONS

- 10GBASE-BX at 10.3125Gb/s
- 10GBASE-BX at 9.953Gb/s

STANDARD

- SFP+ MSA Compliant
- SFF-8472 reversion 9.5 compliant
- IEEE802.3-2005 compliant
- Telcordia GR-468-CORE compliant
- FCC47CFR Part15, Class B compliant
- FDA21CFR 1040.10 and 1040.11, class1 compliant
- RoHS compliant

PRODUCT DESCRIPTIONS

SFP+ 10G 40KM 1270 is hot pluggable 3.3V Small-Form-Factor transceiver module. It designed expressly for high-speed communication applications that require rates up to



10.7Gbps, it designed to be compliant with SFF-8472andSFP+MSA. The module data link up to 40km in 9/125um single mode fiber. The optical output can be disabled by a LVTTTL logic high-level input of Tx Disable. TxFault is provided to indicate that degradation of the laser. Loss of signal(LOS) output is provided to indicate the loss of an input optical signal of receiver or the link status with partner.

FUNCTIONAL DIAGRAM

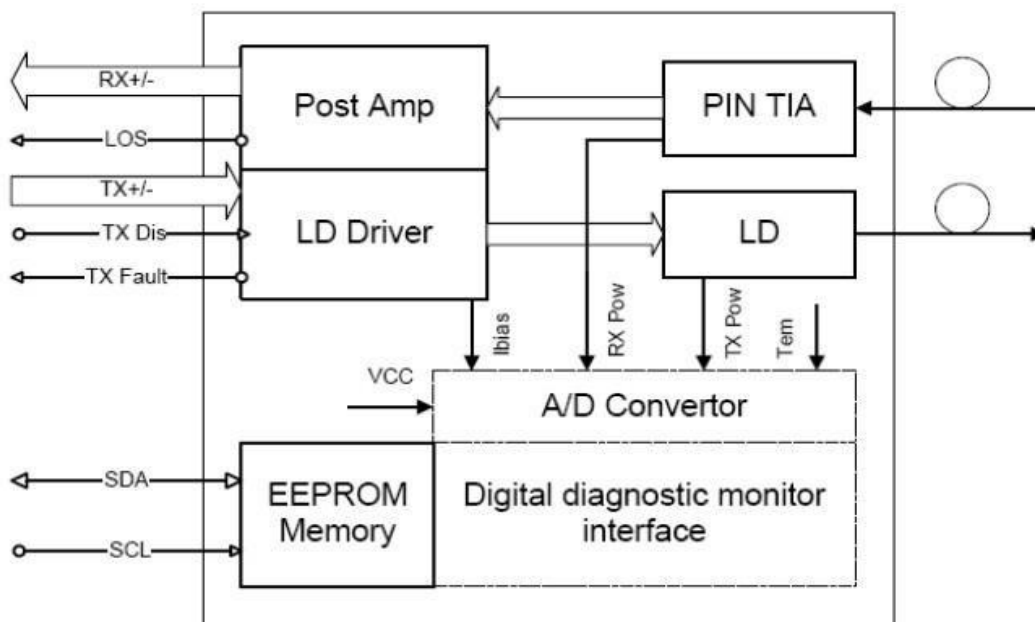

ABSOLUTE MAXIMUM RATINGS

Parameter	Symbol	Min.	Max.	Unit	Note
Supply Voltage	Vcc	-0.5	4.0	V	
Storage Temperature		-40	85	°C	
Relative Humidity			85	%	

Note: Stress in excess of the maximum absolute ratings can cause permanent damage to the module



GENERAL OPERATING CHARACTERISTICS

Parameter	Symbol	Min.	Typ	Max.	Unit	Note
Data Rate	Ethernet		10.3125		Gb/s	
	Fiber Channel		9.953			
Supply Voltage	V _{cc}	3.13	3.3	3.47	V	
	V _{cc}				V	
Supply Current	I _{cc_s}				mA	
	I _{cc_s}			400	mA	
Operating Case Temp.	T _c	0		70	°C	

ELECTRICAL INPUT/OUTPUT CHARACTERISTICS

Transmitter

Parameter	Symbol	Min.	Typ	Max.	Unit	Note
Diff. input voltage swing		120		820	mVpp	1
Tx Disable input	H	V _{IH}	2.0	V _{cc} +0.3	V	
	L	V _{IL}	0	0.8		
TxFault output	H	V _{OH}	2.0	V _{cc} +0.3	V	2
	L	V _{OL}	0	0.8		
Input Diff. Impedance	Z _{in}		100		Ω	

Receiver

Parameter	Symbol	Min.	Typ	Max.	Unit	Note
Diff.output voltageswing		340	650	800	mVpp	3
RxLOSOutput	H	V _{OH}	2.0	V _{cc} +0.3	V	2
	L	V _{OL}	0	0.8		

Note1)TD+/- are internally AC coupled with100Ω differential termination inside the module.

Note2)TxFault and RxLOS are open collector outputs, which should be pulled up with 4.7k to10kΩ resistors on the host board. Pull up voltage between2.0V and V_{cc}+0.3V.

Note3)RD+/- outputs are internally AC coupled, and should be terminated with100Ω(differential)at the user SERDES.



OPTICAL CHARACTERISTICS

Transmitter(0~70 @10.3125Gb/s)

Parameter	Symbol	Min.	Typ	Max.	Unit	Note
Operating Wavelength			1270		nm	
Ave.output power(Enabled)	Po	-2		+3	dBm	1
Extinction Ratio	ER	3.5			dB	1
RMS spectral width	$\Delta\lambda$			1	nm	
Rise/Falltime(20%~80%)	Tr/Tf			50	ps	2
Optical modulation amplitude	OMA	-5.2			dBm	
Dispersion penalty				1	dB	
Output OpticalEye	IEEE802.3-2005Compliant					

Receiver(-5~70 @10.3125Gb/s)

Parameter	Symbol	Min.	Typ	Max.	Unit	Note
Operating Wavelength			1330		nm	
Sensitivity	Psen			-15	dBm	3
Min. overload	Pimax	0.5			dBm	
LOS Assert	Pa	-30			dBm	
LOS De-assert	Pd			-17	dBm	
LOSHysteresis	Pd-Pa	0.5		5	dB	

Note1) Measured at 10.3125Gb/s with PRBS231-1NRZ test pattern. Note2) 20%~80%
 Note3) Under the ER worst case, measured at 10.3125Gb/s with PRBS231 -1NRZ test pattern for BER<1x10⁻¹²



SERIAL INTERFACE FOR ID AND DDM

The SFP modules implement the 2-wire serial communication protocol as defined in the SFP MSA. The serial ID information of the SFP modules and Digital Diagnostic Monitor parameters can be accessed through the I2C interface at address A0h and A2h. The memory is mapped in Table 1. Detailed ID information (A0h) is listed in Table 2. And the DDM specification (A2h) is described in Table 3. For more details of the memory map and byte definitions, please refer to the SFF-8472 (Rev 9.3, Aug. 2002), “Digital Diagnostic Monitoring Interface for Optical Transceivers”.

The DDM parameters have been internally calibrated.

Table 1. Digital Diagnostic Memory Map (Specific Data Field Descriptions)

2 wire address 1010000X (A0h)		2 wire address 1010001X (A2h)	
Address	Information	Address	Information
0~95	Serial ID Defined by SFP MSA (96 bytes)	0~55	Alarm and Warning Thresholds (56 bytes)
96~127	Vendor Specific (32 bytes)	56~95	Calibration Constants (40 bytes)
128~255	Reserved, SFF8079 (128 bytes)	96~119	Real Time Diagnostic Interface (24 bytes)
		120~127	Vendor Specific (8 bytes)
		128~247	User Writable EEPROM (120 bytes)
		248~255	Vendor Specific (8 bytes)

PIN DEFINITIONS AND FUNCTIONS

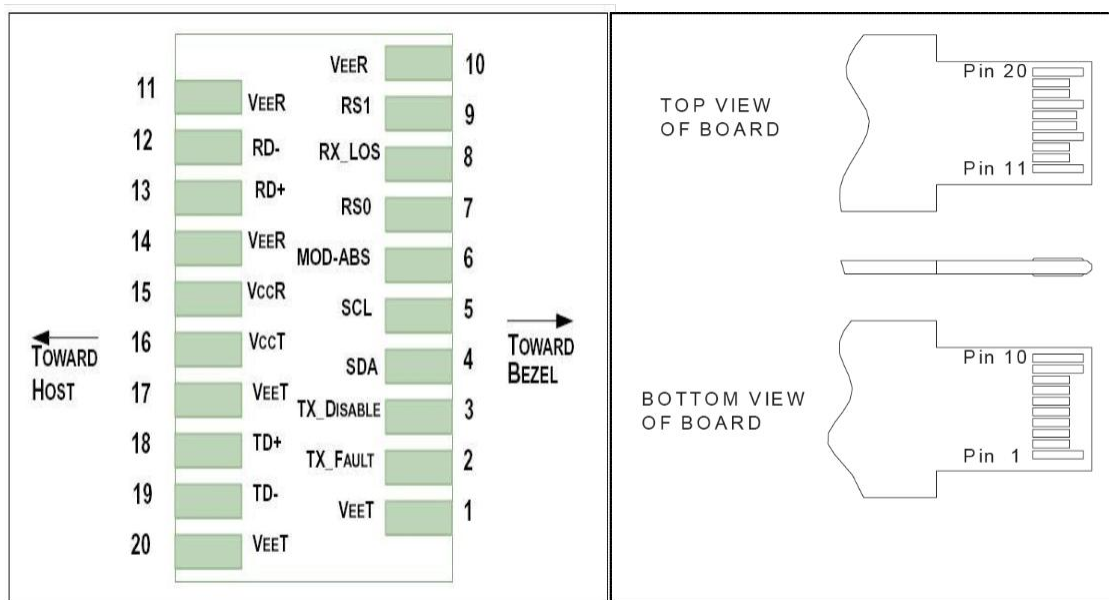



PIN #	Name	Function	Notes
1	VeeT	Module transmitter ground	Note 1
2	Tx Fault	Module transmitter fault	Note 2
3	Tx Disable	Transmitter Disable; Turns off transmitter laser output	Note 3
4	SDL	2 wire serial interface data input/output (SDA)	
5	SCL	2 wire serial interface clock input (SCL)	
6	MOD-ABS	Module Absent, connect to VeeR or VeeT in the module	Note 2
7	RS0	Rate select0,optionally control SFP+ receiver. When high, input data rate >4.5Gb/s;when low, input data rate <=4.5Gb/s	
8	LOS	Receiver Loss of Signal Indication	Note 4
9	RS1	Rate select0,optionally control SFP+ transmitter. When high, input data rate >4.5Gb/s;when low, input data rate <=4.5Gb/s	
10	VeeR	Module receiver ground	Note 1
11	VeeR	Module receiver ground	Note 1
12	RD-	Receiver inverted data out put	
13	RD+	Receiver non-inverted data out put	
14	VeeR	Module receiver ground	Note 1
15	VccR	Module receiver 3.3V supply	
16	VccT	Module transmitter 3.3V supply	
17	VeeT	Module transmitter ground	Note 1
18	TD+	Transmitter inverted data out put	
19	TD-	Transmitter non-inverted data out put	
20	VeeT	Module transmitter ground	Note 1

Note1)The module ground pins shall be isolated from the module case.

Note2)This pin is an open collector/drain output pin and shall be pulled up with4.7K-10Kohmsto Host_Vcc on the host board.

Note3)This pin shall be pulled up with4.7K-10Kohms to VccTin the module.

Note4)This pin is an open collector/drain output pin and shall be pulled up with4.7K-10Kohms to Host_Vcc on the host board. In FC designated as RX_LOS, in SONET designated as LOS, and in Ethernet designated at Signal Detect.

TYPICAL INTERFACE CIRCUIT

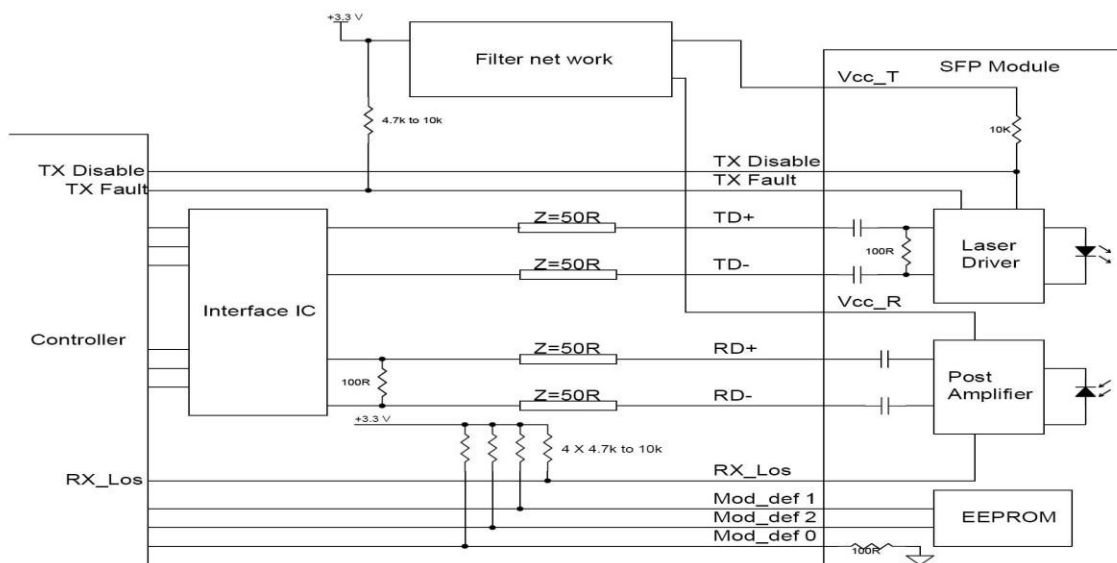



Recommended power supply filter

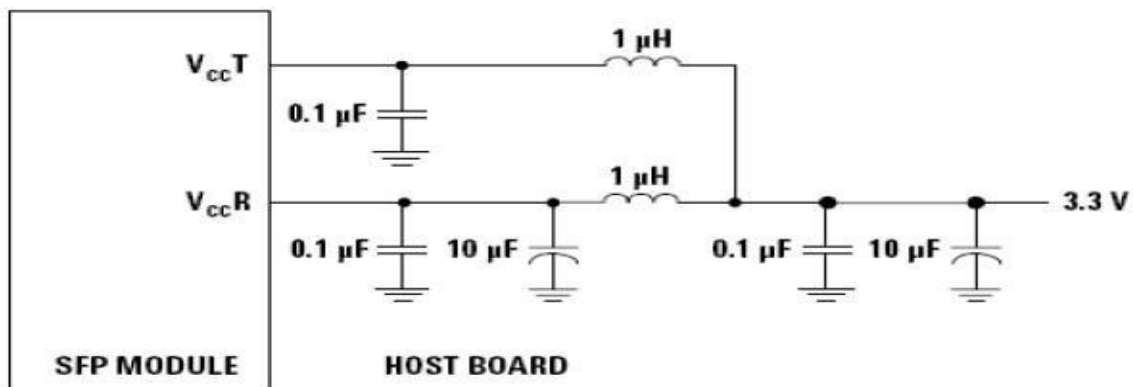

Note: Inductors with DC resistance of less than 1Ω should be used in order to maintain the required voltage at the SFP input pin with 3.3V supply voltage. When the recommended supply filtering network is used, hot plugging of the SFP transceiver module will result in an inrush current of no more than 30mA greater than the steady state value

PACKAGE DIMENSIONS

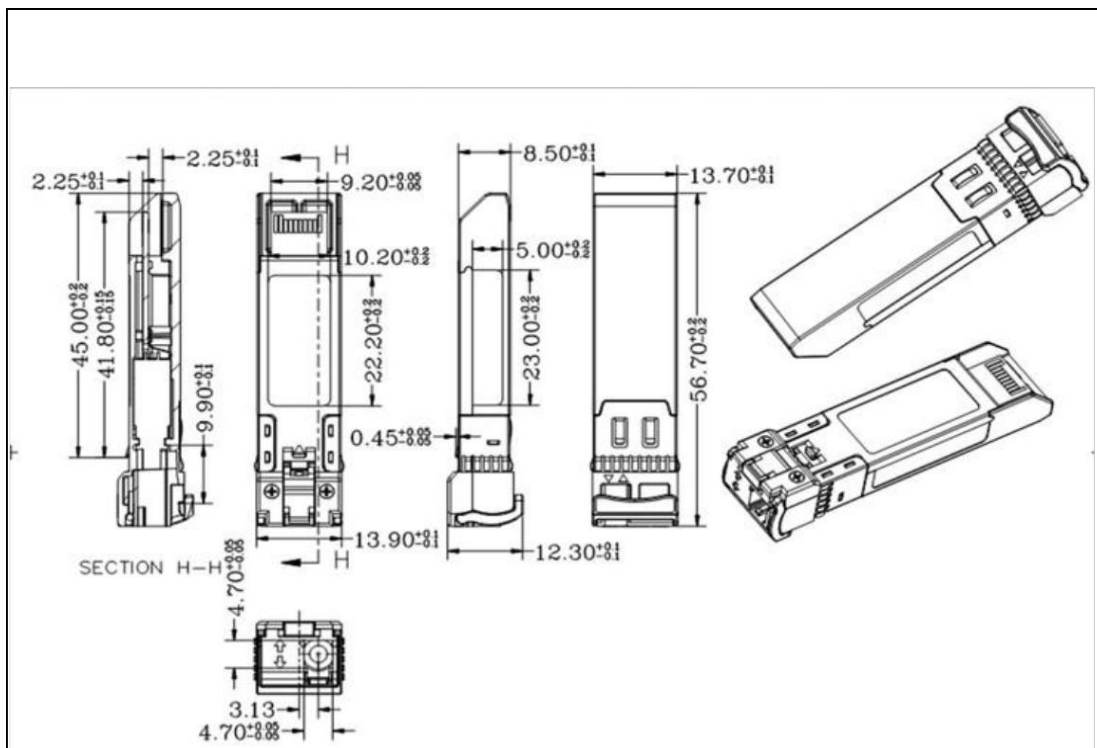



ORDERING INFORMATION

PartNumber	Description
SFP+10G 10KM 1270	SFP+ Plus BiDi, 10.3125Gbps, 1270nm, 10KM, 0~70°C, with DDM
SFP+10G 10KM 1330	SFP+ Plus BiDi, 10.3125Gbps, 1330nm, 10KM, 0~70°C, with DDM
SFP+10G 20KM 1270	SFP+ Plus BiDi, 10.3125Gbps, 1270nm, 20KM, 0~70°C, with DDM
SFP+10G 20KM 1330	SFP+ Plus BiDi, 10.3125Gbps, 1330nm, 20KM, 0~70°C, with DDM
SFP+10G 40KM 1270	SFP+ Plus BiDi, 10.3125Gbps, 1270nm, 40KM, 0~70°C, with DDM
SFP+10G 40KM 1330	SFP+ Plus BiDi, 10.3125Gbps, 1330nm, 40KM, 0~70°C, with DDM
SFP+10G 60KM 1330	SFP+ Plus BiDi, 10.3125Gbps, 1330nm, 60KM, 0~70°C, with DDM
SFP+10G 60KM 1330	SFP+ Plus BiDi, 10.3125Gbps, 1330nm, 60KM, 0~70°C, with DDM



TOPSTAR TECHNOLOGY INDUSTRIAL CO., LIMITED

Topstar Technology Industrial Co., Ltd

Add: F5, Rongcheng Building, 28 Yayuan Road Wuhe Community, BanTian Street, Shenzhen, China

Tel: +86 755 8255 2969 Email:lisa@topsf.com

Skype: lisalin6565 Whatsapp: +86 13798265065

Wechat: 251081707

Facebook and Linked in: Topstar Technology Industrial Co., Ltd

