



TOPSTAR TECHNOLOGY INDUSTRIAL CO., LIMITED

# 产 品 规 格 书

## *Product Specification Sheet*

### TOP-BIDI-XFP-ER+-60A

RoHS Compliant 10Gb/s XFP TX1270nm/RX1330nm 60km Optical Transceiver



E-mali : [csale@topsf.com](mailto:csale@topsf.com)





## **PRODUCT FEATURES**

- Hot pluggable
- Support 9.95Gb/s to 11.1Gb/s bit rates
- Below <1.8w power consumption
- XFPMSA package with LC connector
- Digital Diagnostic Monitor Interface
- Very low EMI and excellent ESD protection
- Un-cooled 1270nmDFB laser and APD receiver
- +3.3V single power supply
- operating temperature range 0°C to 70°C
- No reference clock requirement

## **APPLICATIONS**

- 10GBASE-BX10.3125Gb/s Ethernet
- 10GBASE-BX9.953Gb/s Ethernet
- SONETOC-192 & SDH STM I-64.1

## **STANDARD**

- XFPMSA Compliant
- SFF-8472 reversion 9.5 compliant
- IEEE802.3-2005 compliant
- Telcordia GR-468-CORE compliant
- FCC47CFR Part15, Class B compliant
- FDA21CFR 1040.10 and 1040.11, class 1 compliant
- RoHS compliant



## PRODUCT DESCRIPTIONS

- XFP 10G 60KM 1270 transceivers are designed for 10GEthernet 10GBASE-ZR/ZW per802.3 ae and 10GSOIOC-192/ SDHSTM-64,and it can support data rate from 9.953Gb/s to 11.1Gb/s. Digital diagnostics are available via I2C interface as specified in the XFPMSA.
- The transceiver designs are optimized for high performance and cost effective to supply customers the best solutions for data-comand telecom applications.

## FUNCTIONAL DIAGRAM

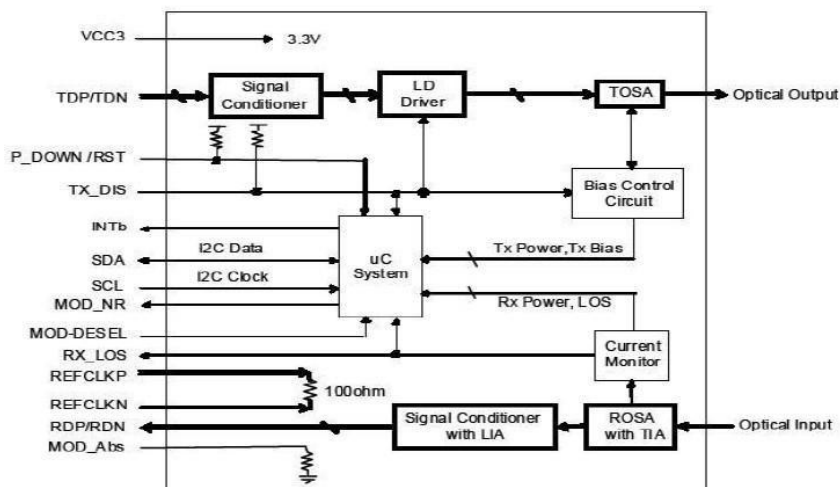

## ABSOLUTE MAXIMUM RATINGS

Parameter	Symbol	Mi	Max	Unit	Note
Supply Voltage	Vc	-0.5	4.0	V	
Storage Temperature		-40	85	°C	
Relative Humidity			85	%	

Note: Stress in excess of the maximum absolute ratings can cause permanent damage to the module



### GENERAL OPERATING CHARACTERISTICS

Paramet	Symbol	Min.	Typ	Max.	Unit	Note
Data Rate	Ethernet		10.3125		Gb/s	
	Fiber Channel		9.953			
Supply Voltage	Vc	3.14	3.3	3.46	V	
	Vcc				V	
Supply Current	Icc <sub>s</sub>				mA	
	Icc <sub>o</sub>			500	mA	
Operating Case Temp.	Tc	0		70	°C	

### ELECTRICAL INPUT/OUTPUT CHARACTERISTICS

#### Transmitter

Paramete	Symbol	Min.	Typ	Max.	Unit	Note
Diff. input voltage swing		120		820	mVpp	1
Tx Disable input	H	VIH	2.0	Vcc+0.3	V	
	L	VIL	0	0.8		
Tx Fault output	H	VOH	2.0	Vcc+0.3	V	2
	L	VOL	0	0.8		
Input Diff. Impedance	Zin		100		Ω	

#### Receiver

Paramete	Symbol	Min.	Typ	Max.	Unit	Note
Diff. output voltage swing		340	650	800	mVpp	3
Rx LOS Output	H	VOH	2.0	Vcc+0.3	V	2
	L	VOL	0	0.8		

Note1)TD+/-are internally AC coupled with100Ω differential termination inside the module.

Note2)Tx Fault and Rx LOS are open collector outputs, which should be pulled up with4.7k to10kΩ resistors on the host board. Pull up voltage between 2.0V and Vcc+0.3V.

Note3)RD+/- outputs are internally AC coupled, and should be terminated with100Ω(differential)at the user SERDES.



### OPTICAL CHARACTERISTICS

#### Transmitter(0~70 @10.3125Gb/s)

Paramete	Symbol	Min.	Typ	Max.	Unit	Note
Operating Wavelength		1260	1270	1280	nm	
Ave. output power(Enabled)	Po	0		5	dBm	1
Extinction Ratio	ER	3.5			dB	1
RMS spectral width	$\Delta\lambda$			1	nm	
Rise/Fall time(20%~80%)	Tr/Tf			50	ps	2
Optical modulation amplitude	OMA	-5.1			dBm	
Dispersion penalty				2	dB	
Output Optical Eye	IEEE802.3-2005Compliant					

#### Receiver(0~70 @10.3125Gb/s)

Paramete	Symbol	Min.	Typ	Max.	Unit	Note
Operating Wavelength		1320	1330	1340	nm	
Sensitivit	Psen			-20	dBm	3
Min. overload	Pimax	-7			dBm	
LOS Assert	Pa	-38			dBm	
LOS De-assert	Pd			-21	dBm	
LOS Hysteresis	Pd-Pa	0.5		4	dB	

Note1)Measured at10.3125b/s withPRBS2<sup>31</sup>-1NRZ test pattern.

Note2)20%~80%

Note3)Under the ER worst case, measured at10.3125Gb/s with PRBS 2<sup>31</sup> -1 NRZ test pattern for BER< 1x10<sup>-12</sup>



## SERIAL INTERFACE FOR ID AND DDM

The XFP modules implement the 2-wire serial communication protocol as defined in the XFPMSA.

The serial ID information of the XFP modules and Digital Diagnostic Monitor parameters can be accessed through the I2C interface at address A0h and A2h. The memory is mapped in Table 1. Detailed ID information (A0h) is listed in Table 2. And the DDM specification (A2h) is described in Table 3. For more details of the memory map and byte definitions, please refer to the SFF-8472 (Rev 9.3, Aug. 2002), "Digital Diagnostic Monitoring Interface for Optical Transceivers".

The DDM parameters have been internally calibrated.

Table 1. Digital Diagnostic Memory Map (Specific Data Field Descriptions)

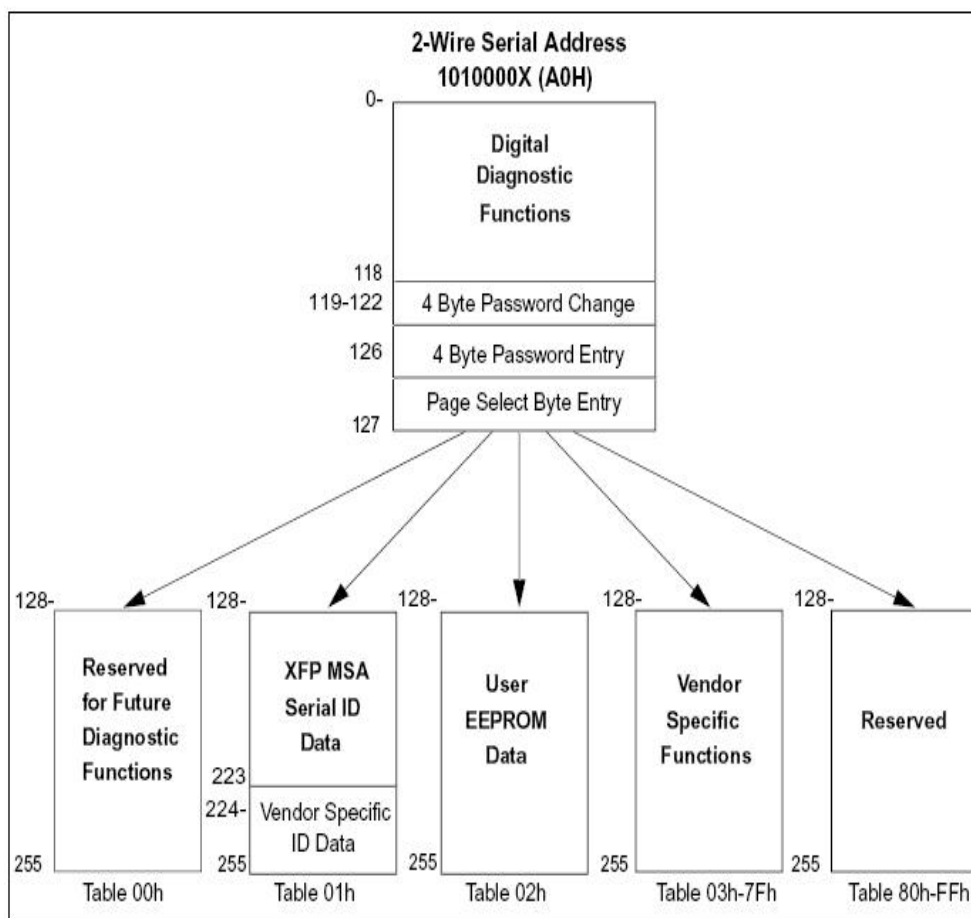



**PIN DEFINITIONS AND FUNCTIONS**

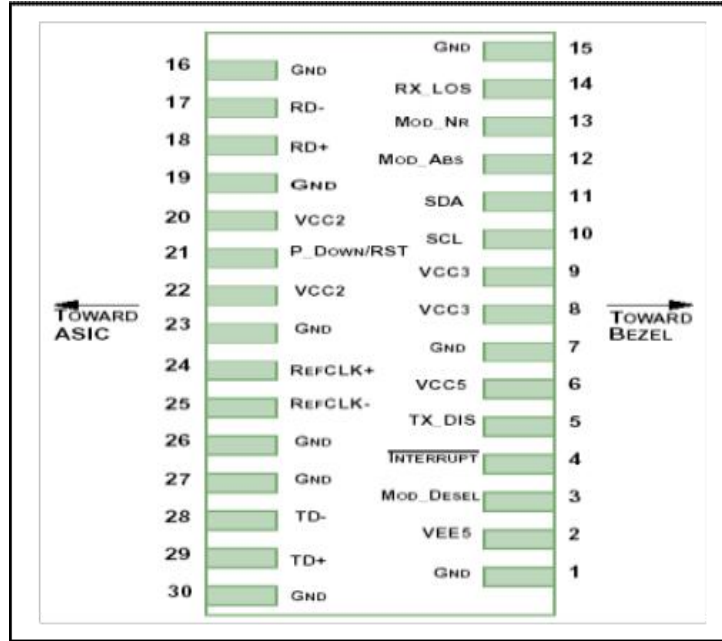

PIN#	Name	Function	Name/Description	Notes
1		GND	Module Ground	1
2		VEE5	Optional-5.2V Power Supply (Not required)	
3	LVTTTL-I	MOD_DESEL	Module De-select; When held low allows the module to respond to 2-wire serial interface	
4	LVTTTL-O	INTb	Interrupt; Indicates presence of an important condition which can be read via the 2-wire serial interface	2
5	LVTTTL-I	TX_DIS	Transmitter Disable; Turns off transmitter laser output	
6		VCC5	+5V Power Supply (Not required)	
7		GND	Module Ground	1
8		VCC3	+3.3V Power Supply	
9		VCC3	+3.3V Power Supply	
10	LVTTTL-I/O	SCL	2-Wire Serial Interface Clock	2
11	LVTTTL-I/O	SDA	2-Wire Serial Interface Data Line	2
12	LVTTTL-O	MOD_Abs	Indicates Module is not present. Grounded in the Module	2
13	LVTTTL-O	MOD_NR	Module Not Ready; Indicating Module Operational Fault	2



14	LVTTTL-O	RX_LOS	Receiver Loss Of Signal Indicator	2
15		GND	Module Ground	1
16		GND	Module Ground	1
17	CML-O	RDN	Receiver Inverted Data Output	
18	CML-O	RDP	Receiver Non-Inverted Data Output	
19		GND	Module Ground	1
20		VCC2	+1.8V Power Supply (Not required).	3
21	LVTTTL-I	P_DOWN/RST	Power down; When high, requires the module to limit power consumption to 1.5 W or below. 2- Wire serial interface must be functional in the low power mode.	
21	LVTTTL-I	P_DOWN/RST	Reset; The falling edge initiates a complete reset of the module including the 2-wire serial interface, equivalent to a power cycle.	
22		VCC2	+1.8V Power Supply (Not required)	3
23		GND	Module Ground	1
24	PECL-I	REFCLKP	Not used, internally terminated to 50ohm (100ohm diff).	4
25	PECL-I	REFCLKN	Not used, internally terminated to 50ohm (100ohm diff).	4
26		GND	Module Ground	1
27		GND	Module Ground	1
28	CML-I	TDN	Transmitter Inverted Data Input	
29	CML-I	TDP	Transmitter Non-Inverted Data Input	
30		GND	Module Ground	1

Note: 1. Module ground pins GND are isolated from the module case and chassis ground within the module.

2. Open collector; Shall be pulled up with 4.7K-10Kohms to a voltage between 3.15V and 3.6V on the host board.

3. The pins are open within module.

4. Reference Clock is not required.





### TYPICAL INTERFACE CIRCUIT

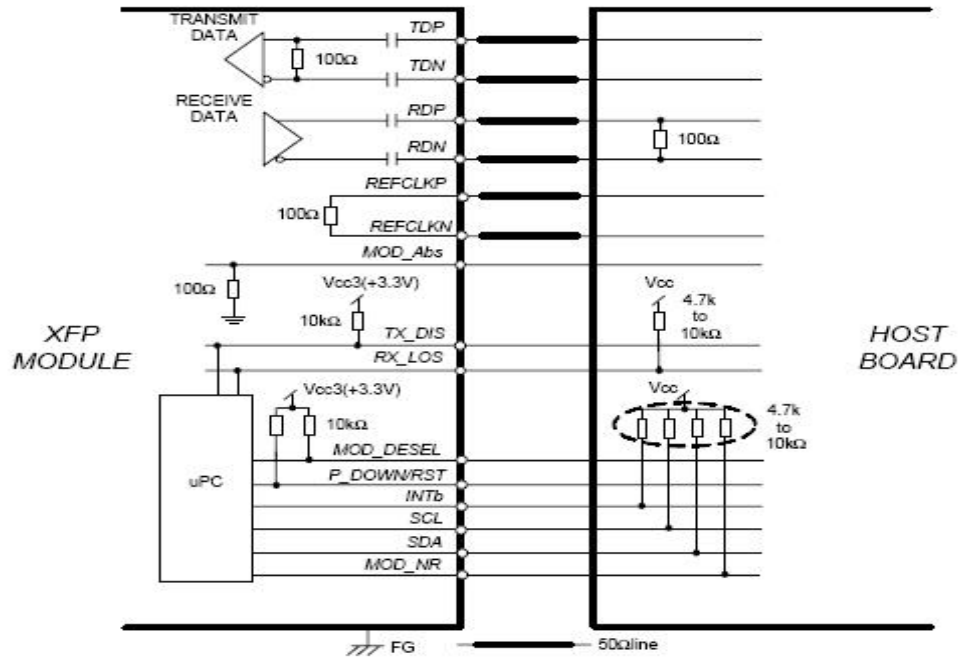

### PACKAGE DIMENSIONS

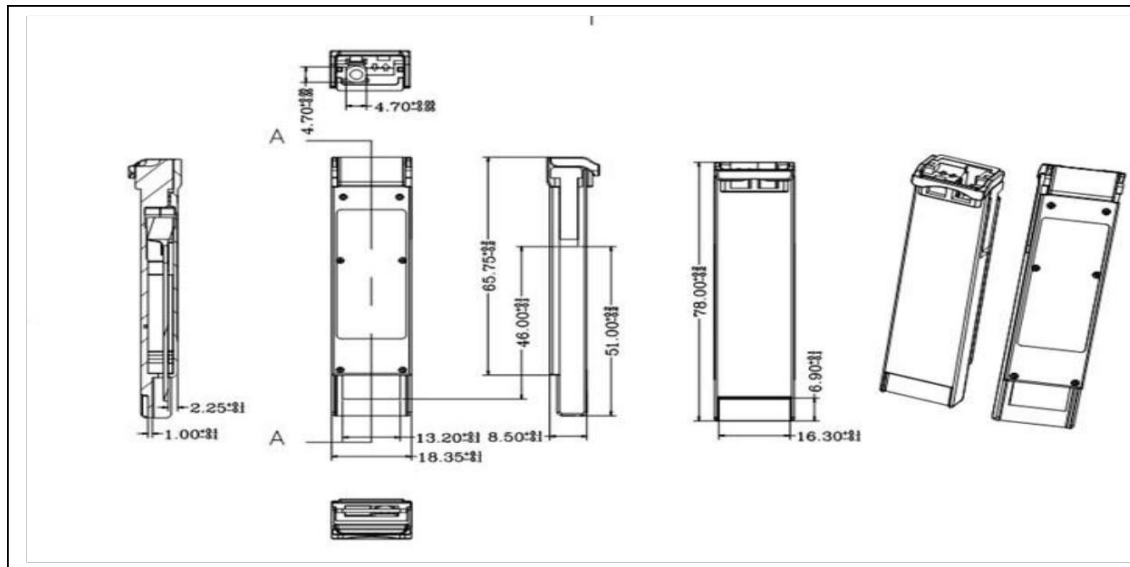



## ORDERING INFORMATION

Part Number	Description
TOP-BIDI-XFP-20A	XFP BiDi, 10.3125Gbps, 1270nm, 20KM, 0~70°C, with DDM
TOP-BIDI-XFP-20B	XFP BiDi, 10.3125Gbps, 1330nm, 20KM, 0~70°C, with DDM
TOP-BIDI-XFP-ER-40A	XFP BiDi, 10.3125Gbps, 1270nm, 40KM, 0~70°C, with DDM
TOP-BIDI-XFP-ER-40B	XFP BiDi, 10.3125Gbps, 1330nm, 40KM, -5~70°C, with DDM
TOP-BIDI-XFP-ZR-80A	XFP BiDi, 10.3125Gbps, 1270nm, 80KM, -5~70°C, with DDM
TOP-BIDI-XFP-ZR-80B	XFP BiDi, 10.3125Gbps, 1330nm, 80KM, -5~70°C, with DDM



**TOPSTAR TECHNOLOGY INDUSTRIAL CO., LIMITED**

## **Topstar Technology Industrial Co., Ltd**

**Add: F5, Rongcheng Building, 28 Yayuan Road Wuhe Community, BanTian Street, Shenzhen, China**

**Tel: +86 755 8255 2969 Email: [lisa@topsfp.com](mailto:lisa@topsfp.com)**

**Skype: [lisalin6565](https://www.skype.com/people/lisalin6565) WhatsApp: +86 13798265065**

**WeChat: 251081707**

**Facebook and Linked in: Topstar Technology Industrial Co., Ltd**

